

INFORMATION AND COMMUNICATION TECHNOLOGY OFFICE

Annual Highlights of Accomplishment Report FY 2022

1. Information Systems Development

- a) Development of Document Tracking System – an in-house developed system to track documents using QR codes.
 - A presentation was conducted in Dec. 2022 online to some concerned users. Users were asked to test the system themselves
 - It has been assessed to the Privacy Impact Assessment (PIA) team
 - It is for actual testing however some features are being implemented based on the comments of PIA team; users now can request for user accounts via eMail to ict.office@bsu.edu.ph
 - System information help is found at <https://sites.google.com/bsu.edu.ph/dtshelp/home?pli=1>

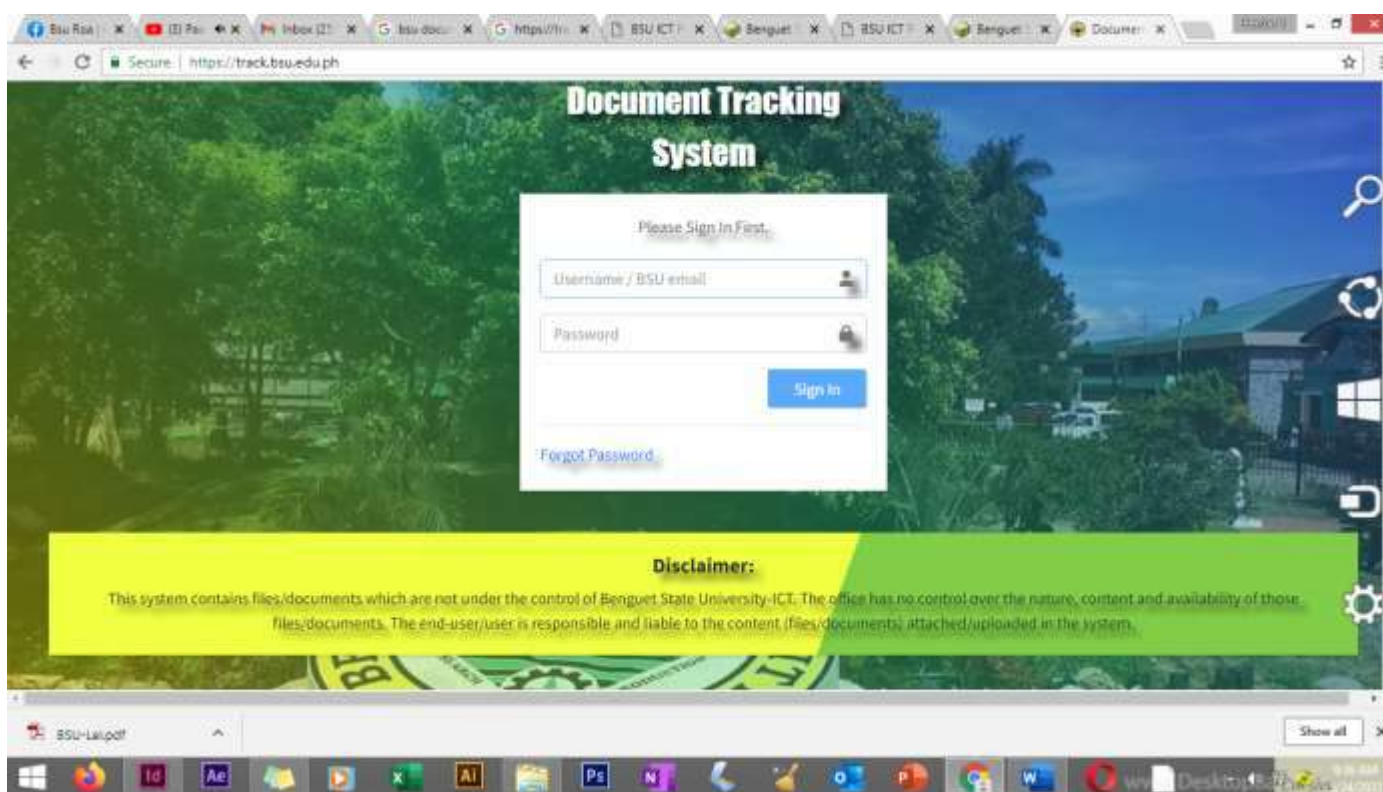
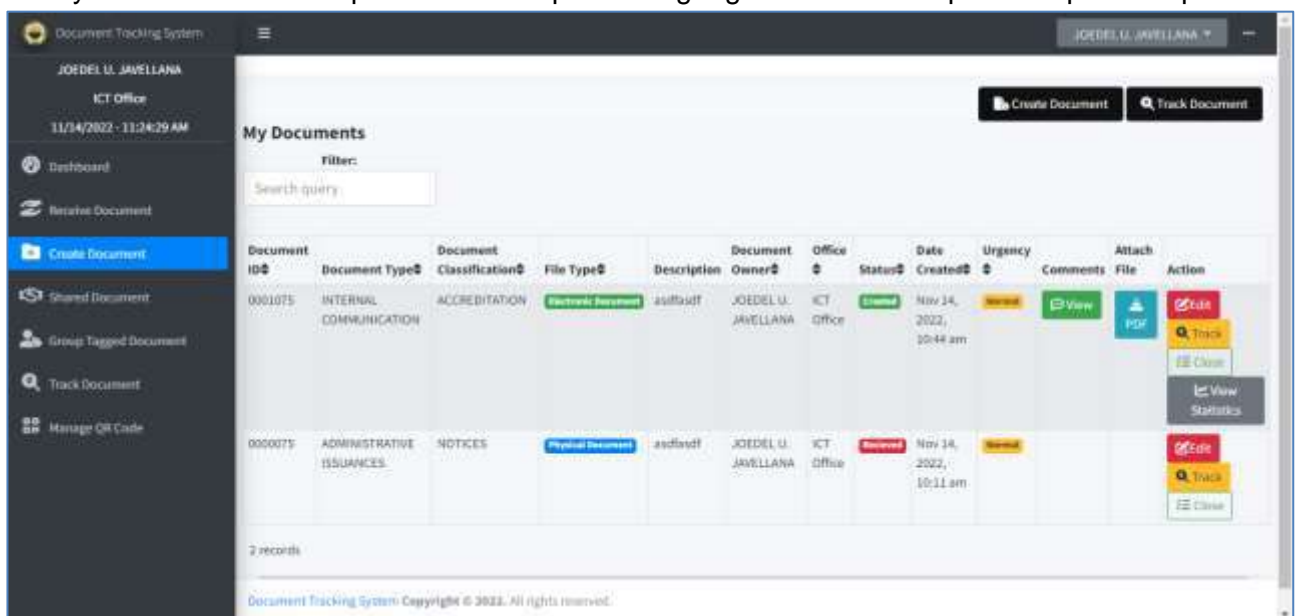

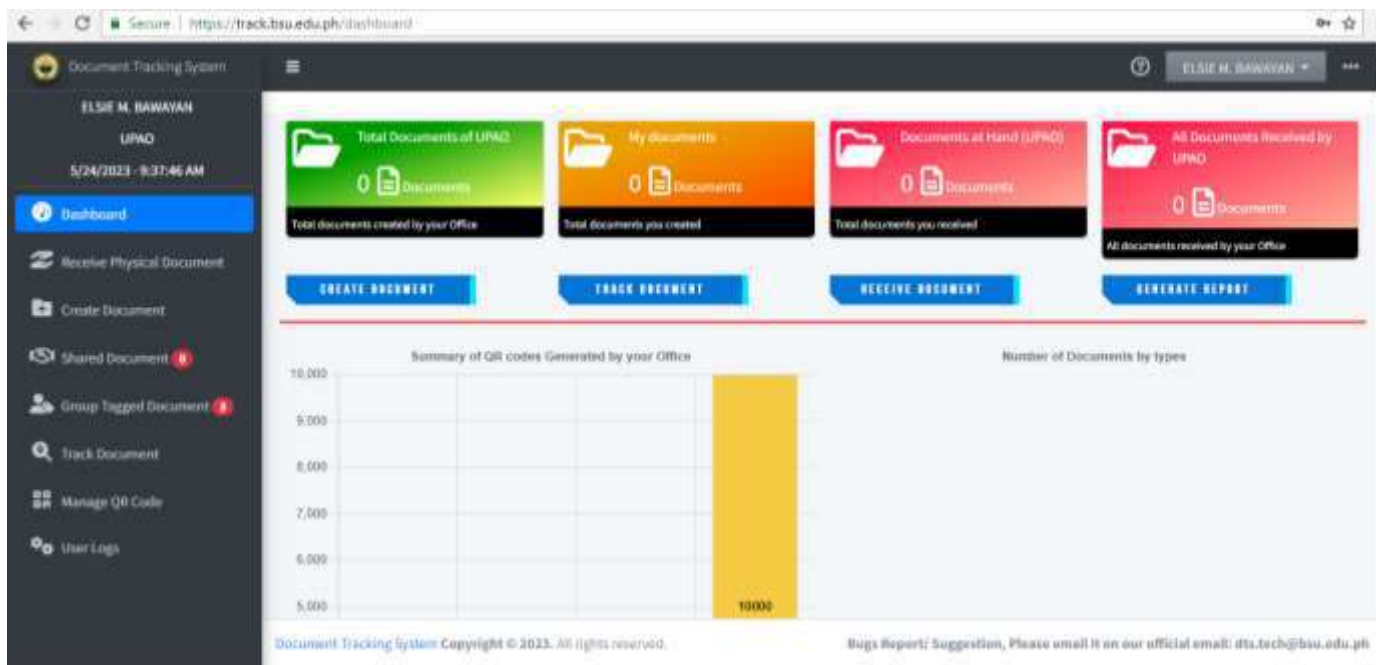

b) Development of Research Profiling System (RePS)

- RePS is a system where university research journals and research applications are stored and managed online, and generate data and reports. Main functions are to store journals and register new researches.
- It was presented to the REXECOM on Jan. 19, 2023; 10:30 am at the Carnation; a committee chaired by VP. John Dati has been created and is composed of researchers and ICT.
- RePS is already installed in the university official cloud server with the aim of stabilizing its availability and security.
- It is subject for PIA assessment.
- It can be accessed in its temporary server at : <https://rps.bsutempserver.info/> Username: rpsusr Password: rp123456



c) Upgrading of online ICT laboratory monitoring system – this is an in-house system which records the logs of student when they use the different internet laboratories location in various colleges and locations in the university. This make it easier for the university to monitor students using the facilities.

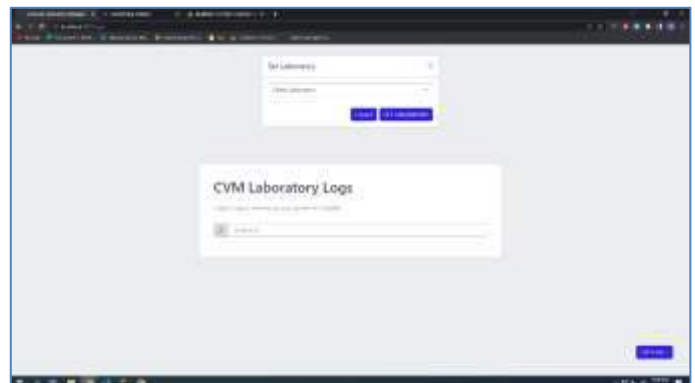
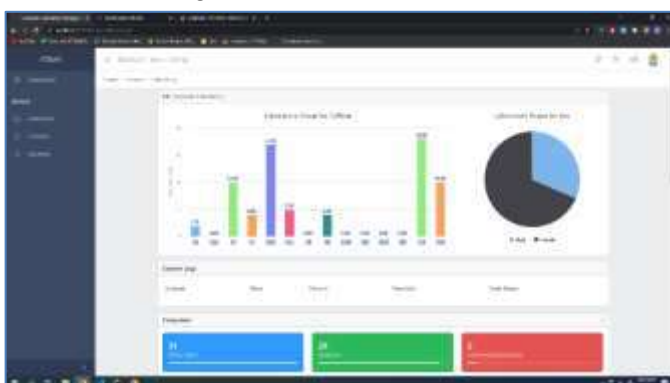

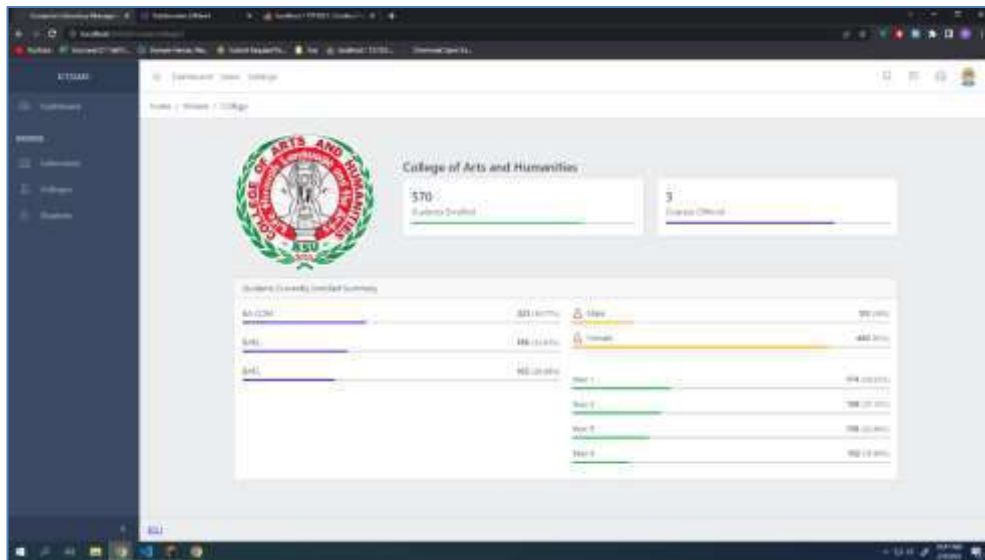

d) Updating of the Accreditation Webpage

- For easier management and organization of files, various links and storage areas were created, a dedicated website was also created for easy access by accreditors and accretees.
- The system can be accessed at <https://accreditation.bsu.edu.ph>



e) SDG Content integration to the university website

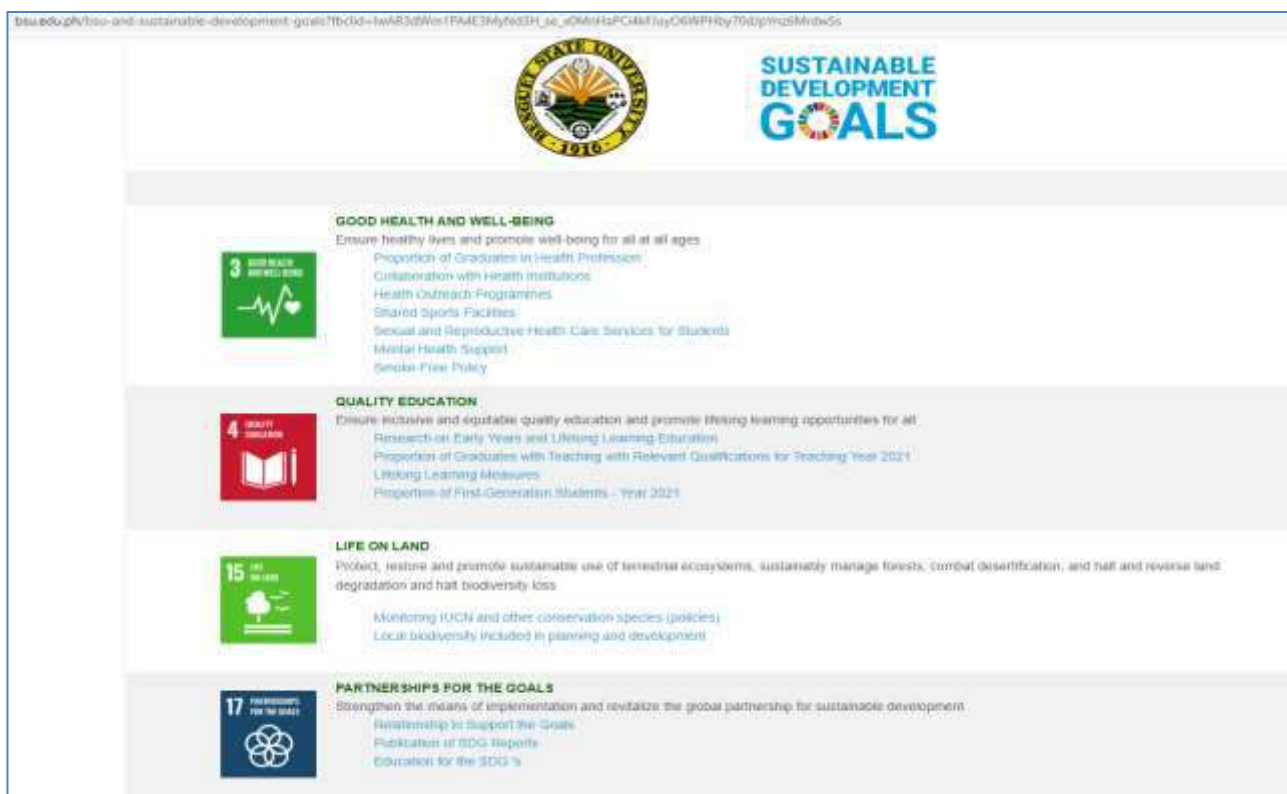

f) **Sustenance of Existing Information Systems** – the following systems have been installed by the university and currently, they are functional.

- Online Request System (gatekeeper.bsu.edu.ph) – used by ICT to manage request for technical support.
- Digital Asset Management System (dams.bsu.edu.ph) – contains various university documents e.g. memos, templates, files and others
- Online Journal Repository (journals.bsu.edu.ph) – contains BSU research journals
- Librisource – a facility to search for scientific journals, books and information on the web. This was deployed in BSU in partnership with the University of Leuven. This can be accessed at <http://portal.bsu.edu.ph:8080/>
- Digital Library – can be accessed at <http://portal.bsu.edu.ph:8081/greenstone/cgi-bin/library.cgi>

2. **IT Infrastructure Development** - Acquisition of official university Virtual Private Server cloud and Cloud Webhosting

- the infrastructure is used to host various online information systems ensuring 24/7 availability and security. Currently, the inventory system, document tracking, research profiling, and student laboratory monitoring system are hosted here. All other system will gradually follow.

3. **Internet Service Deployment/Upgrade**

- Installed data and 100-150 Mbps at the ICT Office as upgrade and replacement of the old line, and added a 300 Mbps new DSL internet service at the IHFSA and 100 Mbps at the CE student internet laboratory. This is to provide a backup, alternative or to augment the current internet service.

4. **Disaster Risk Management strategies**

- Installation of a security Smart Device at the Network Operations Center which will notify and alert concerned staff in the event of fire, smoke, and motion.
- The system can be controlled via call or SMS by an authorized staff and staff will as well receive notification and warnings via SMS.



Figure 1. Alarm System at ICT-NOC

5. Partnerships Sustainability

- a. Smart Telecommunication – active free university WiFi service
- b. Department of Information and Communications Technology (DICT)
 - Free WiFi and network installed the college of engineering from first to 3rd floor; it is composed of 5 wireless routers and is used by students for their internet access.
 - Conducted free ICT training with university employees from the General Services Offices (admin aides)
- c. Weavetech Technologies Inc
 - Free sponsorship of 4 ICT staff participation in ICT training in ICT Security.
 - Free internet bandwidth boost during major university events.
 - Active internet provider
- d. Commission on Higher Education/St. Benilde – Development of Business Continuity Plan for the university (on-going document development).

6. Website Statistics Report

- BSU university visit logs shows 143,654 visitors. Kindly refer to the image below for detailed reports.



Audience Overview

Jan 1, 2022 - Dec 31, 2022

All Users
100.00% Users

Overview

● Users ● New Users

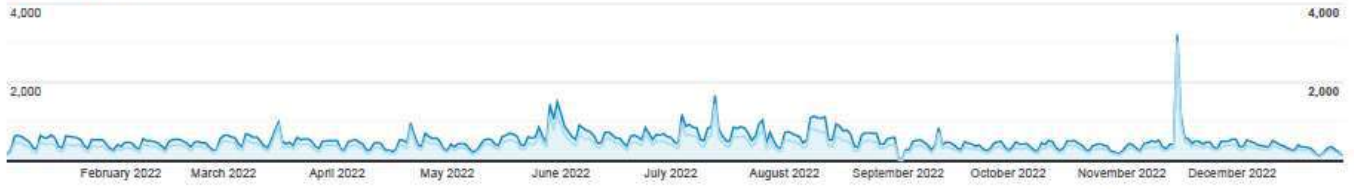

Users 143,654	New Users 141,764	Sessions 216,257	Number of Sessions per User 1.51
Pageviews 547,601	Pages / Session 2.53	Avg. Session Duration 00:02:31	Bounce Rate 50.28%

■ New Visitor ■ Returning Visitor

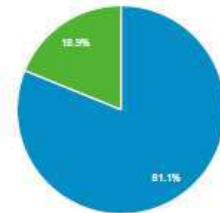

Country	Users	% Users
1. Philippines	122,765	84.48%
2. United States	4,600	3.17%
3. Indonesia	3,631	2.50%
4. China	1,999	1.38%
5. Germany	1,623	1.12%
6. United Kingdom	1,019	0.70%
7. Hong Kong	709	0.49%
8. (not set)	640	0.44%
9. France	632	0.43%
10. Canada	600	0.41%

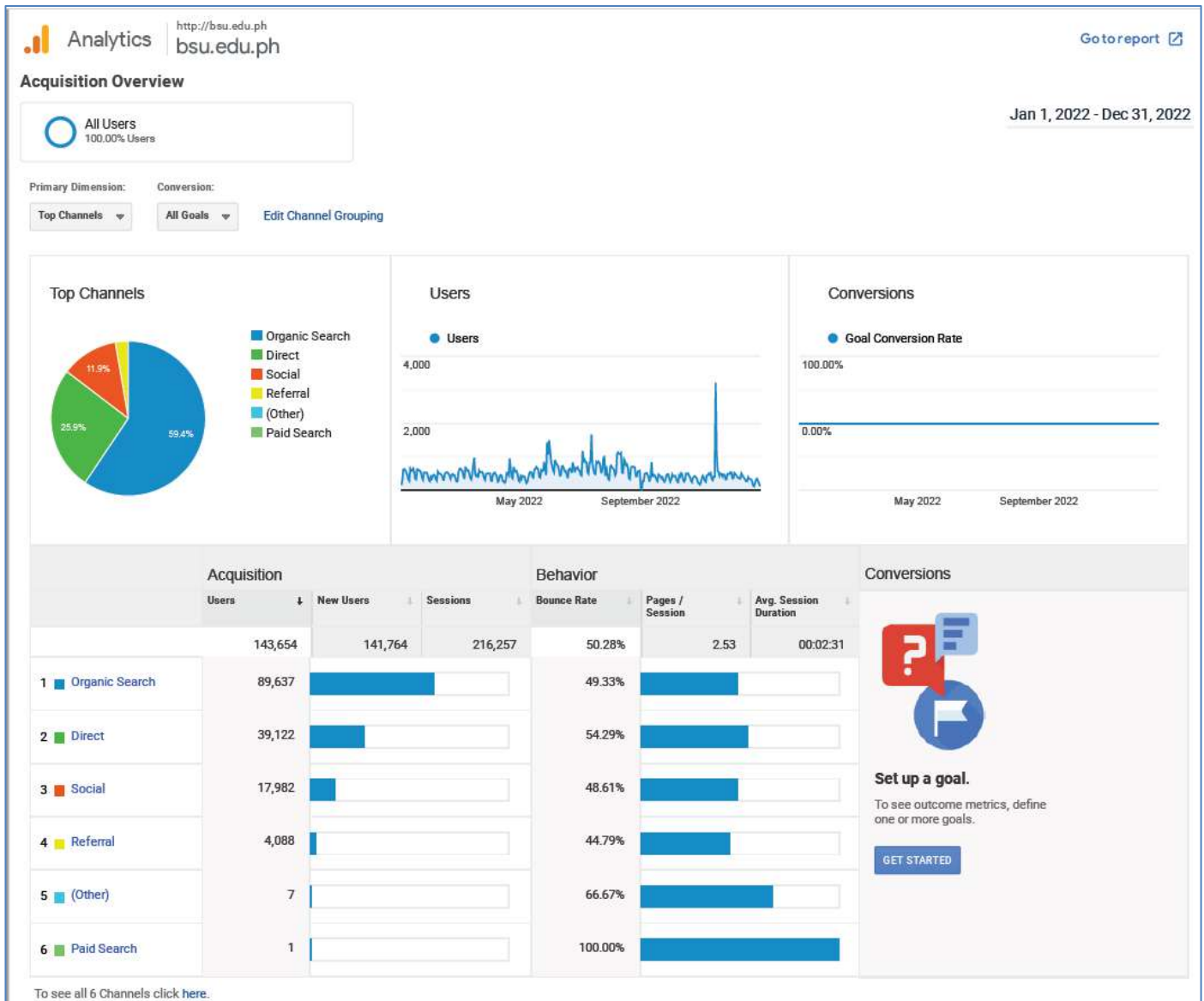

7. **Benguet State University Web Ranking in the Philippines – BSU is ranked # 32 from 33 last year.**

ranking	World Rank	University	Det.	Impact Rank*	Openness Rank*	Excellence Rank*
24	5794	National University Philippines	👉	11898	5403	5666
25	5801	University of San Jose Recoletos	👉	7772	5943	6057
26	5851	University of Science and Technology of Southern Philippines USTP	👉	15031	4543	5512
27	5887	Pangasinan State University	👉	13517	4927	5666
28	5915	Ateneo de Davao University	👉	7109	6551	5848
29	5946	Western Mindanao State University	👉	12444	6551	5081
30	6002	Cavite State University	👉	12216	4878	5942
31	6045	Isabela State University	👉	10996	5242	6057
32	6065	Benguet State University	👉	10877	5348	6057
33	6183	(3) University of the Philippines Mindanao	👉	8572	6551	5848
34	6257	Fatima University	👉	11373	6551	5512
35	6275	Bulacan State University	👉	11828	4922	6191
36	6305	Holy Angel University	👉	11029	6157	5942
37	6401	Cagaya State University	👉	13880	4842	6057
38	6452	Asia Pacific College	👉	7514	6551	6191
39	6539	Jose Rizal University	👉	8842	6551	6057

8. **Human Resource Information System Technical Support**

- Procurement of a cloud server for the Recruitment, Selection and Placement Module of the HRIS. It is accessible through the cloud link at <https://rsp.bsu.edu.ph>.

- *Note: HRIS development is under HRMO; ICT provides technical support.*



9. Policy Created and Updated:

- Information Systems Policy.
- Google Drive Usage Policy.
- Bring Your Own Device (BYOD) Policy.
- Network Operations Center Policies and Procedures.
- Development of the Business Continuity Plan (BCP) ICT for BSU in partnership with CHED and in partnership with St. Benilde University.
 - o Organization of BSU team for the Business Continuity Plan ICT for BSU
 - o Development of the BCP documentation
 - o Updated of key metrics and re-arranged the list of items according to the priority of the priority system to be restored in case of disaster
 - o Updating of ratings based on facts and as identified by the mentor

10. Network Infrastructure Development

- La Trinidad, Campus Network Improvements
 - Five (5) locations upgraded from 1Gbps to 10Gbps. (CN, ULIS, CN lib, CVM lib, old CHET)
 - Four (4) locations LAN upgraded from 100 Mbps to 1Gbps (SLS, NSTP, UHS, CCA)
 - Fifteen (15) Equipment Upgrades.
 - Sixty-two (62) Wireless Network Expansions
 - Installed fifteen (15) dual-frequency MikroTik cAP ac access points at the following Administration Offices/Locations
 - Deployed four (4) additional MikroTik cAP ac devices at the former College of Arts & Sciences Annex.
 - Deployed one (1) additional MikroTik cAP ac device at the CTE-DSE.
 - Deployed four (4) additional MikroTik cAP ac devices at the Office for Student Services.
 - Deployed six (6) additional MikroTik cAP ac devices at the old College of Home Economics & Technology building.
 - Deployed four (4) MikroTik cAP ac devices at the CTE-SLS.
 - Deployed one (1) MikroTik RB951Ui-2Hnd wireless router at the NSTP Office
 - Deployed one (1) MikroTik cAP ac at the Anthurium Hall.
 - Replaced four (4) 2.4GHz wireless devices and upgraded them to two (2) dual-frequency MikroTik cAP ac access points at the following Administration Offices/Locations:
- Improvement of Bokod and Buguias, Local Area Network – the LAN of both campuses were upgraded from 100Mbps backbone to 1Gbps backbone.
 - Twenty-three (23) equipment upgrades were made for Bokod Campus while Buguias had 25 upgrades.

Bokod Campus New LAN Infrastructure

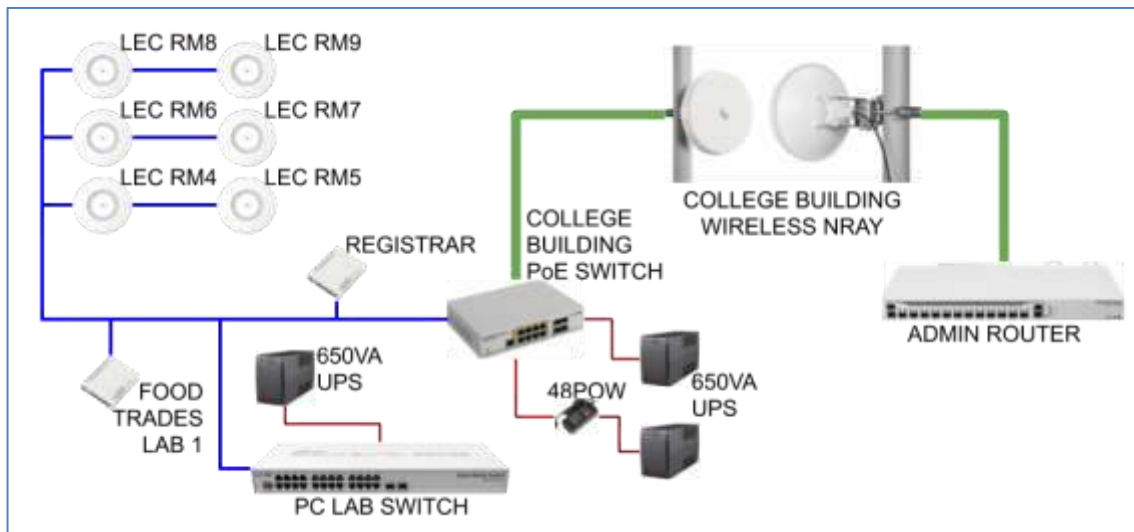
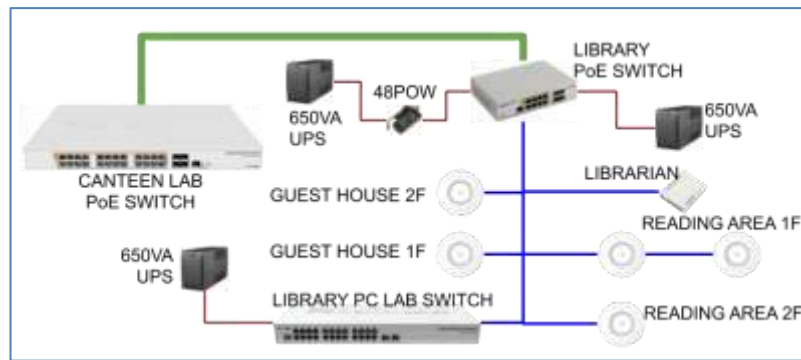
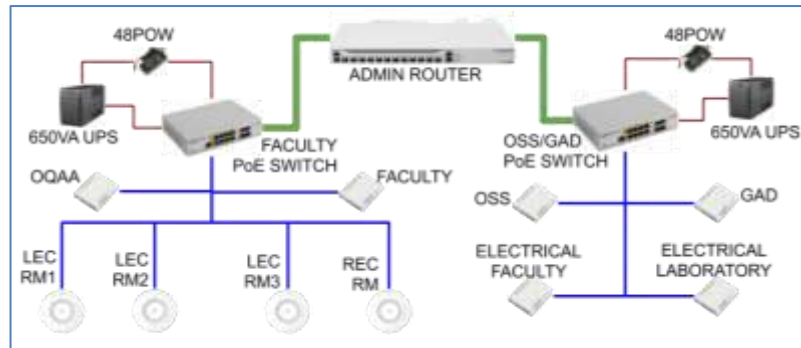
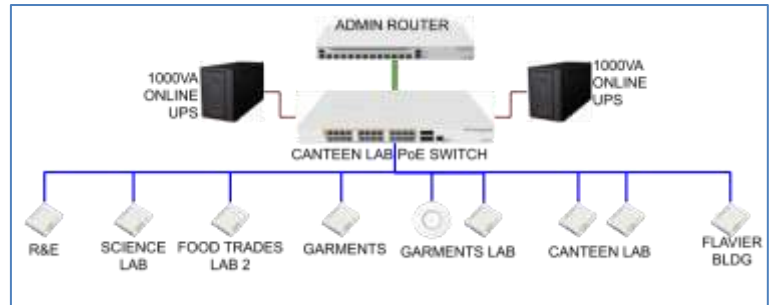
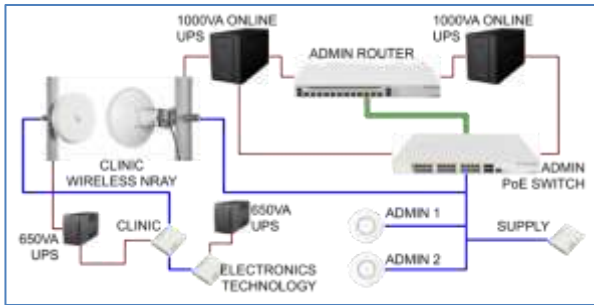

Buguias Campus New LAN Infrastructure

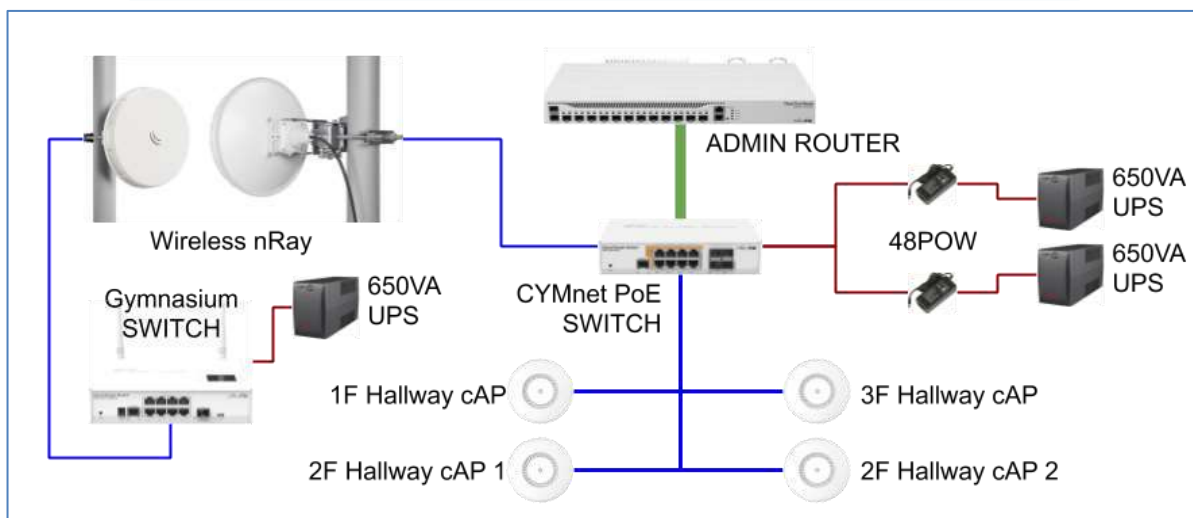
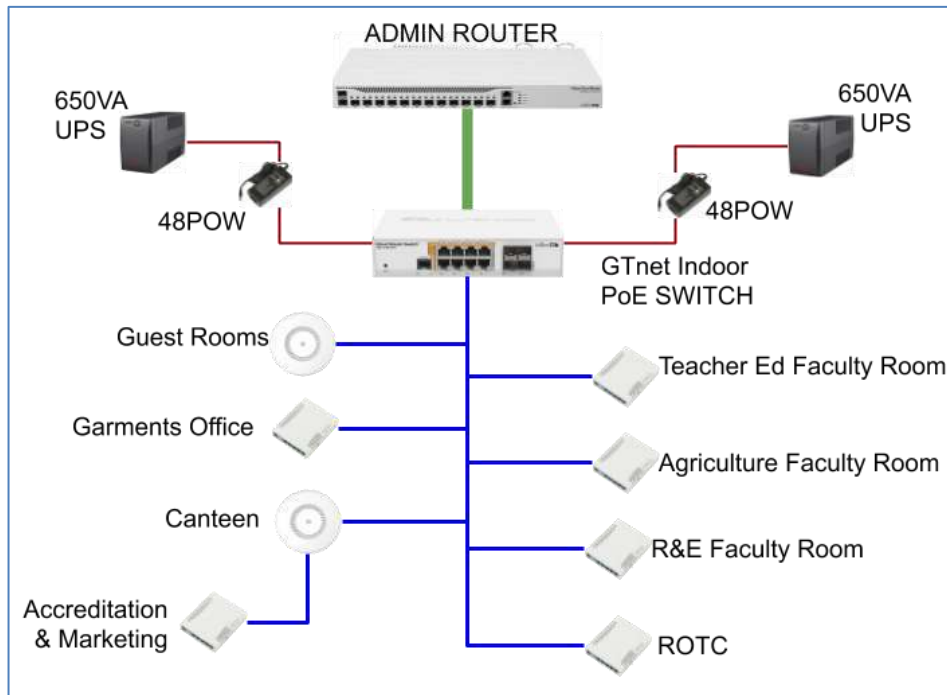
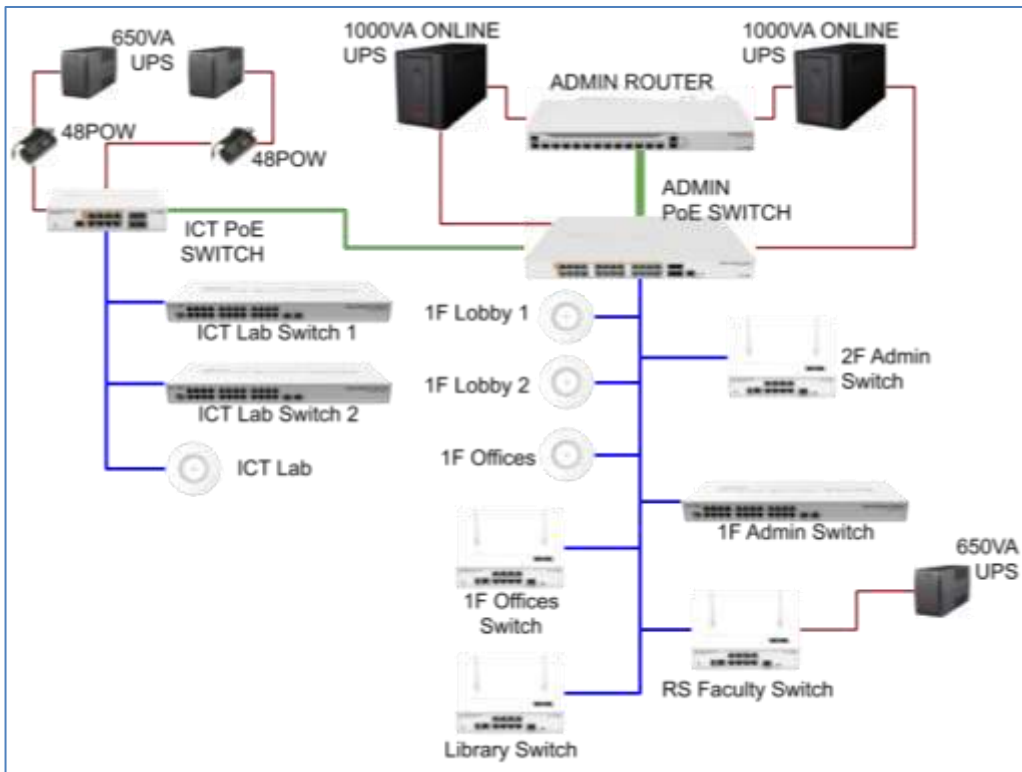

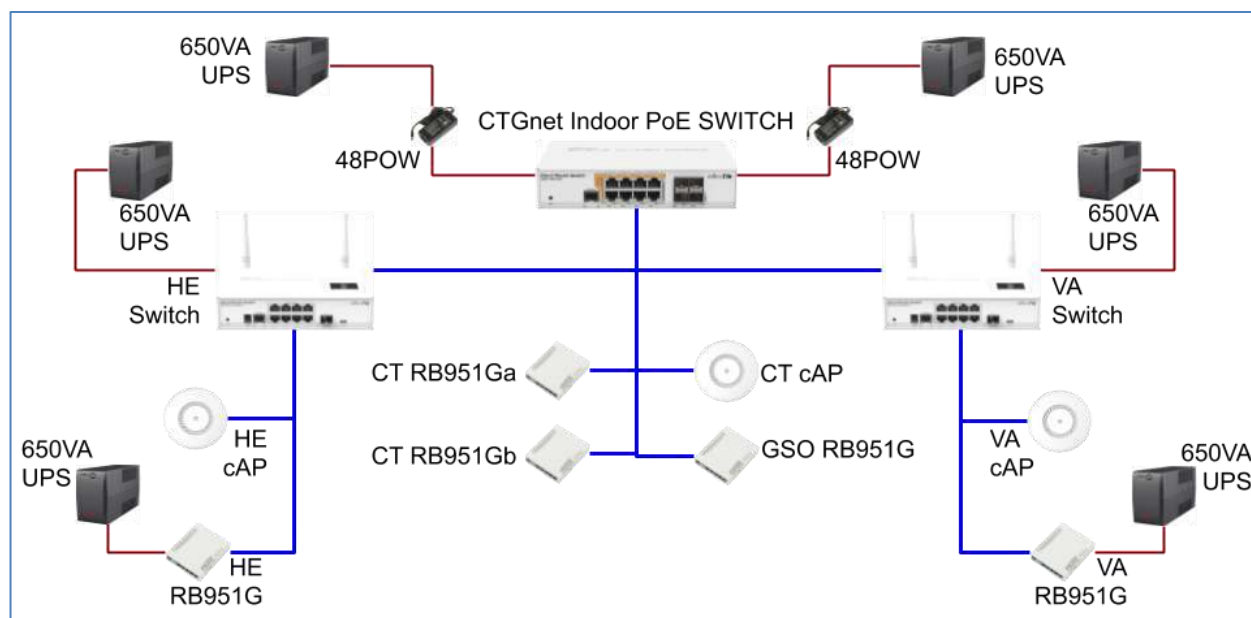

11. Other Accomplishments

- QMS document updated for the ISO onsite Audit in October 2022
- Upscaling ICT Infrastructure of CoRRCAARD
 - consultation with mam Flor on the details of the High-LEvel diagram (Sept 12 2022)
- Updated the ICT Infrastructure Development plan for PCAARD and RnE, joined the TWG evaluation committee on this project and updated the proposal
- Created and updated the proposal for ICT equipment for procurement under the For Later Release fund

PLANNING AND DEVELOPMENT OFFICE

I. PLANNING

A. OFFICE ORGANIZATIONAL CHART AND FUNCTION

- ✚ Prepared the proposed Office Organizational Chart and Function of the Project Management Unit and Planning Unit
- ✚ Prepared Position Description for the created position for the Project Management Unit and Planning Unit as per NBC 586

B. PERFORMANCE MANAGEMENT

Highlights	Remarks
1. Compiled OPCR/DPCRs for Jan-Dec 2022 Rated, Jul-Dec 2022 Targets and 2022 Operational Plans	<ul style="list-style-type: none"> - Summary of submission of performance rating and target transmitted to the concern sectors - Assist some DUs in the preparation of their Operation Plan, OPCR and DPCR
2. Consolidated revisions on the University Strategic Plan 2021-2024	<ul style="list-style-type: none"> - Strategic Plan Matrix created - Presented during the Sectoral Management Reviews
3. Consolidated Strategic Plan Accomplishments for CY 2021	
4. Incorporate updates identified by the Academic and Admin & Finance sector during the mid-year planning / Management Review.	<ul style="list-style-type: none"> - Provided copies of the Strat Plan to all sectors
5. Digitization of performance management records for ease of transaction a. OPCR/ DPCR (rated & target) 2013-2022	<ul style="list-style-type: none"> - Provided copy to HRDO for the PM PRIME – HRM Level II Accreditation

b. Summary of Ratings (January-December 2021) c. Monitoring Reports on the Readiness of Delivery Units for Evaluation	
6. Developed SPMS Documents Transmittal Form	<ul style="list-style-type: none"> • Used for reminding delivery units who fail to submit • Used for transmittal of individual OPCR/ DPCR performance rating • Used to communicate results of individual OPCR/ DPCR assessment

C. PREPARATION OF TECHNICAL DOCUMENTS FOR INFRASTRUCTURE PROJECTS

1. Prepared 2 Terms of Reference (TOR)
 - CVM Hospital (design and build project)
 - TOR for lease (Commercial lot)

2. Service Provided as per Request of Clients

➤ Prepared design plans & cost estimates for the following projects:	
1. Proposed Repair & Renovation of CTE Building	19. Renovation of Covered Court
2. Proposed Renovation of Land Bank (Third Floor)	20. Demolition of Comfort Room at Closed Gym
3. Construction of Biodiversity Research Center-Phase II	21. Proposed Secondary Gate & Perimeter Fencing of the College Dorm
4. Proposed Concreting and Tiling of the New Clinic Bldg. Parking Area	22. Demolition of BAPTC signage tower
5. Proposed Farm shop (CA)	23. Repair of the CTE-ELS; Main and Home Economic, Health and Science Building
6. Proposed Coffee Shop	24. Covered Walkway (Main gate to Outpost)
7. Grading and Gravelling of the Pay Parking Area	25. VIP Dining Room
8. Construction / Extension of Ticket Booth	26. Proposed Gazebo at Centennial
9. Proposed Water Tank Tower & Water Tank w/ Stand - CHET (RSDC Canteen), Bakery, & FPC	27. Proposed Diffused Light Yam Storage
10. Furniture Designs at BSU College Dormitory	28. Various Repairs at University Business Affairs
11. FPC Drainage	29. Proposed Elevated Walkway
12. Proposed Roof Canopy (Old Clinic)	30. Proposed Repair at the ICT Room
13. Proposed Diffused Light Yam Storage	31. Repair of the CF Open Laboratory
14. Renovation of Covered Court	32. Proposed Secondary Room Cabinet
15. Demolition of Comfort Room at Closed Gym	33. Proposed Conference Room Table
16. Proposed Secondary Gate & Perimeter Fencing of the College Dorm	34. Proposed Renovation of the Landbank Building (3 rd floor)
17. Demolition of BAPTC signage tower	35. Proposed Grease Tank
18. Proposed Diffused Light Yam Storage	36. Proposed Cooling Tower and Enclosure

➤ Prepared as built floor plans for the following project: 37. CA-DAS Projects

<ul style="list-style-type: none"> ➤ Prepared cost estimates for the following projects: <ul style="list-style-type: none"> 38. Repainting of the Admin, CA, CAS-ANNEX, CAS MAIN, CTE, and RSDC buildings 39. Repair of the BSU College Dormitory 	<ul style="list-style-type: none"> ➤ Prepared design plans for the following project: <ul style="list-style-type: none"> 40. Proposed Office Cubicle Layout (HRMO) 41. Proposed LED TV – Admin Entrance 42. Office Table w/ Acrylic Barrier 43. Proposed Stainless Letterings – Main Gate 44. Proposed Renovation of the ELS Girl’s CR
-----------------------------------------------------------------------------------------------------------------------------------------------------------------------------------------------------------------------------------------------------------------------------------------------------	---------------------------------------------------------------------------------------------------------------------------------------------------------------------------------------------------------------------------------------------------------------------------------------------------------------------------------------------------------------------------------------------------------------------

- Monitored and prepared necessary documents for the completion of the following projects:

Completed Projects	Date of Implementation
1. Construction and Site Improvement of the Benguet Agri-Pinoy Trading Center (BAPTC) Minimal Processing and Packaging Facility through Design	April 16, 2021 – December 31, 2021
2. Construction of Information Technology Building	December 13, 2021 – August 15, 2022
3. Expansion of the College of Forestry Building	August 15, 2021-December 30, 2022
4. Repair and Improvement of BAPTC Spot Trading Building 1	May 12, 2022 – July 15, 2022
5. Repair and Improvement of BAPTC Spot Trading Building 2 & 3	March 24, 2022 – May 30, 2022
6. Repair and Improvement of BAPTC Dormitory Building	May 17, 2022 – July 16, 2022
7. Repair of the BSU Water Tank at Tabangaoen, Balili	August 15, 2022 – October 09, 2022

II. MONITORING AND EVALUATION

A. INFRASTRUCTURE PROJECTS

- Monitored and prepared necessary documents for the completion of the following projects:

Completed Projects	Date of Implementation
2019 Completed Projects (For release of 10% retention)	
1. Repair of the CN-Roof Deck/ Canopy	February 13, 2020 – June 15, 2020
2. Repair of the CVM –Backstage of Anatomy	February 22, 2020 – July 23, 2020
3. Repair of CHET Access Road	September 7, 2020 - October 7, 2020
2021 Completed Projects	
4. Deep Well Drilling Project at BAPTC	December 29, 2020-April 18, 2021 (For release of 10% retention)
5. Renovation & Upgrading of the University Canteen I	January 4, 2021 - June 8, 2021 (For final billing)
6. Electrical Enhancement of the Laboratory Rooms and the R &D Complex	August 17, 2021 – October 19, 2021 (For release of 10% retention)
7. Construction and Site Improvement of the Benguet Agri-Pinoy Trading Center (BAPTC) Minimal Processing and Packaging Facility through Design	April 16, 2021 – December 31, 2021
8. Expansion of the College of Forestry Building	August 24, 2021 – December 31, 2022
2022 Completed Projects	
9. Repair of 1 unit Greenhouse & Supply, Delivery & Installation of Aeroponics System	January 4, 2021-January 24, 2022
10. Repair & Improvement of the BSU Bokod Road Network	January 21, 2022 – March 4, 2022
11. Pakyaw Labor for the Construction of Pergola Signage and Photobooth	October 22, 2021 - March 25, 2022

12. Construction of Biodiversity Research Center, Bokod Campus –Phase I	August 12, 2021 – April 7, 2022
13. Repair of Riprap along the BSU College of Forestry Nursery	January 26, 2022 – April 26, 2022
14. Proposed PCR Room & Generator House	January 27, 2022 - April 19, 2022
15. Repair and Improvement of BAPTC Spot Trading Building 2	March 24, 2022 – May 25, 2022
16. Repair and Improvement of BAPTC Spot Trading Building 3	March 24, 2022 – May 25, 2022
17. Construction of BSU Agri-Processing Center – Phase I	December 17, 2020 – June 8, 2022
18. Repair of the BSU Water Tank at Tabangaoen, Balili	August 15, 2022 – October 9, 2022

III. MANAGEMENT INFORMATION SYSTEM



A. Processed and transmitted data required by oversight agencies

Particulars	Submitted		
	To	Deadline	On
1. BSU's Physical and Financial Accomplishment Report (RPMES)	NEDA-CAR	20-January-2023 (4 th Quarterly)	Updated thru the eRPMES system
2. Submission of priority programs and projects (PAPs) for inclusion in the Updated 2017-2020 Public Investment Program (PIP)	NEDA-PIPOL System		Mar-2022
3. List of Proposed Repair Works for 2023 (Tier 1)	Budget Office/DBM		Mar-2022
4. BP Forms -Table 3: Report on CSO's Inputs on Ongoing & New Spending Projects & Activities -Revised BP Form 202	Budget Office/DBM	Communication received on February 7, 2022	25-March-2022
5. Infrastructure Updates	COA	Jul-Sept (Quarterly)	05-Oct-2022
6. Facilitated the updating of RDIP Chapters 8&14 for the 2021 Regional Development Report	NEDA-CAR	22-Apr-2022	20-Apr-2022 05-May-2022
7. Authorization Form for PIP 2023-2028 and TRIP FY 2024-2026 Focal(s)	NEDA-CAR	31-Oct-2022	02-Nov-2022
8. Submission of Priority Programs and Projects (PAPs) for inclusion in the Updated PIP 2023-2028 Public Investment Program (PIP)	NEDA-PIPOL System	27-Nov-2022	25-Nov-2022

B. Accomplished inventory of office records (1966 to 2022) and submitted to Records Office and Archives for consolidation of valueless records for disposal.

C. Included in the PDO Database the available floorplans and building permits

D. Revised the EODB of the external services of the Office:

-  Request for Variation Order
-  Request for Billing
-  Request of Documents/Data /Services

E. Updated the Risk Management Documents of the Office

IV. OTHER MATTERS

1. Spearheaded and attended concerns on land use and other development activities of the University.
2. Submitted report on the status of implementation of BSU Land Use Plan/ LUDIP for pilot testing for proposed revision of SUC Levelling Instrument.
3. Ongoing provision of the required data needed by the University of the Philippines Resilience Institute (UPRI) in participation of the University to the CHED-funded Safe and Resilient Universities (SAFER-U) Project.
4. Assisted in the processing of DBM requirements for FLR funded projects.

LAND RESERVATION OFFICE

- Reported 25 illegal activities within the University reservation.
- Conducted 5 lot area surveys.
 - Lot area of BFP
 - Animal Science farms
 - Man-iib-a area
 - Barangay Balili
 - Parking area at Tabangaoen
 - Parking area of BSUCMPC
 - ALAPO Nature's Park
- Participated in Joint Relocation Surveys regarding:
 - Mino P. Calgo's claim.
 - Lot boundaries of the Province of Benguet, LGU La Trinidad and DENR.
- Processed tree cutting permits for 4 dead Benguet Pine, 3 Agoho and 1 Jacandra at DENR-CENRO Baguio, Pacdal, Baguio City.
- Inspected and identified reference points of the lot area of the location of the new BSU Kabayan Campus.
- Identified two areas for the establishment of a Calibration site of survey instruments in response to the request of GEP-CAR.
- Prepared and issued 25 document requests from various clients.
- Prepared and issued 41 Lot Certifications outside the BSU reservation.
- Prepared and issued 1, 168 No Adverse Claim Certifications to partners/lessees.
- Recorded and issued 40 Gate passes for construction materials.
- Identified a tree planting site at Talingguroy, Wangal, Lot 2 of the BSU reservation as requested by CTE students.
- Signed 953 Contracts as witness of the University.
- Assisted in the installation of Christmas lights and decorations at the Centennial Park, Administration Building and front of Admin. Bldg. to CAS bldg.

OFFICE OF THE QUALITY ASSURANCE AND ACCREDITATION

A. AACCUP Accreditation

- Coordinated and facilitated the conduct of 3rd Survey Phase 2 Accreditation Survey Visits for: Bachelor of Science in Entrepreneurship, Bachelor of Science in Information Technology, Bachelor of Science in Library and Information Sciences, Master of Arts in Home Economics, Master of Arts in Public Administration, Master of Arts in Technology and Home Economics, Master of Science in Forestry, and Master of Science in Physical Education on February 14-16, 2022

- Coordinated and facilitated the conduct of 3rd Survey Phase 2 Accreditation Survey Visits for: Bachelor of Science in Environmental Science, Master of Arts in Physics, Master of Arts in Applied Statistics, Master of Arts in Mathematics, Master of Science in Biology, Ph.D. Science Education major in Biology, and Master of Arts in General Science on February 16-18, 2022
- Coordinated and facilitated the conduct of Accreditation Survey Visits for: Bachelor of Science in Public Administration (BPA)- 1st survey and Bachelor of Science in Hotel and Restaurant Management (BSHRM)- 2nd Survey on September 12-16, 2022
- Coordinated and facilitated the conduct of Accreditation Survey Visit for Master of Science in Agricultural Economics- 4th Survey Phase 1 Revisit Area III on December 12-14, 2022

B. ISO 9001:2015 Quality Management System

- Coordinated and facilitated the conduct of ISO 9001:2015 QMS External Audit in the university on October 26, 2022
- Coordinated and facilitated the conduct of the ISO QMS Executive Management Review on October 10 to 12, 2022 at the RDC Hall
- Coordinated and facilitated the conduct of the Administration and Finance Sectoral Management Review on September 22 and 28, 2022 at the RDC Hall
- Coordinated and facilitated the conduct of the Academic Sectoral Management Review on September 21, 2022 at the RDC Hall
- Coordinated and facilitated the conduct of the Research and Extension Sectoral Management Review on September 20, 2022 at the R & E Everlasting Hall
- Coordinated and assisted in the conduct of Internal Quality Audit on June – September 2022
- Assisted in the facilitation of Core Process Internal Quality Auditor's meeting on June 8, 2022
- Facilitated and assisted in the conduct of Academic Sector's Revision of their ISO QMS documents
- Conducted and facilitated ISO QMS Orientation/ Re-orientation Training-Workshops on April 18-21, 2022; April 26-27, 2022; and May 4-6, 2022

C. Times Higher Education (THE) Impact Rankings and World's Universities with Real Impact (WURI) Rankings.

- Coordinated and assisted in the preparation of required documents for World's Universities with Real Impact (WURI) to be submitted on November 30, 2022
- Coordinated, facilitated and assisted in the preparation and submission of required documents for Times Higher Education (THE) Impact Rankings on November 11, 2022.
- Coordinated and facilitated the conduct of the THE Committee Workshop on November 3, 2022 at the R & E Everlasting Hall
- Coordinated and facilitated plans, collection of documents and committee meetings for THE and WURI

D. Office concerns

- Conducted office meetings
- Facilitated and coordinated list of participants for the AACCUP's 1st Face to Face Accreditors' BARKADAHAN 2022 on October 19-20, 2022
- Coordinated and facilitated other AACCUP accreditation concerns of colleges and other offices
- Coordinated and facilitated the participation of THE Committee during the Planning Workshop on PQA and THE Impact Rankings at Banaue Ifugao on October 18-20, 2022
- Coordinated and facilitated THE committee meetings

E. Benchmarking

- Assisted the City Government of Baguio on ISO 9001:2015 Quality Management System concerns on April 5, 2022
- Assisted Pangasinan State University by sharing knowledge and experience in QS (Quacquarelli Symonds) Stars Rating System on May 31, 2022

F. SUC Levelling

- Facilitated in the conduct of Pilot-testing by CHED-OIQAG for the proposed revision of the SUC Levelling Instrument

G. Support to University Activities

- Attended the F.I.T. Habit activities of the University
- Attended University meetings as per memos/ advisories for attendance to these

GENDER AND DEVELOPMENT OFFICE

(Benguet State University Gender And Development Plan and Budget 2022 endorsed by PCW)

Client-Focused Activities

1. To increase female students level of participation and awareness on Gender in Sports/ MCW-IRR Section 14 Develop, establish and strengthen programs for the participation of women in competitive and non-competitive sports as means to achieve excellence, promote physical and social well-being
 - Conduct sports activities targeted for female students
 - 3 sports activities attributed from College of Human Kinetics
2. To increase the students' level of awareness and appreciation on GAD /CHED Memo Order No. 01 series 2015
 - Conduct GAD orientation/ forum/ seminar to BSU students
 - Conducted 2022 Freshman Students Onboarding: College Orientation, Gender And Development (GAD) with Adolescent Sexual and Reproductive Health BSU students in collaboration with the Office of Student Services and colleges (face to face/ online 15 colleges and 2 external campus and to the new campuses)
 - College of Arts and Humanities- September 16, 2022
 - College of Engineering- September 8, 2022
 - College of Nursing- September 3, 2022

- College of Information Sciences- September 2, 2022
 - College of Social Science- September 1, 2022
 - College of Public Administration and Governance- September 1, 2022
 - College of Forestry- August 31, 2022
 - College of Veterinary Medicine- August 31, 2022
 - College of Agriculture- August 31, 2022
 - College of Human Kinetics- August 31, 2022
 - College of Teacher Education- August 30, 2022
 - College of Numeracy and Applied Sciences- August 26, 2022
 - College of Natural Sciences- August 26, 2022
 - College of Home Economics and Technology- August 25, 2022
- Orientation on Gender Sensitivity, Road Safety, Drug Prevention and Control; August 25-26, 2022; BSU Bokod Campus, BSU Bokod Kabayan Section
3. To empower student leaders regarding GAD responsive leadership (La Trinidad, Bokod, Buguias Campus) /CHED Memo Order No. 01 series 2015
- Continuous conduct of GAD responsive leadership training for student
 - Conducted GAD responsive 3 leadership training attributed from Office of Student Affairs
4. To sustain GAD-related extension activities delivering technology transfer, Livelihood Program, Technical Assistance, and Advocacy to community partners to help promote gender equality, poverty reduction and sustainable development/ Part VII of CHED Memorandum Order 01, series 2015 on Gender-Responsive Research and Extension Program
- Conduct of Extension project/ activities to partner organizational/ communities as component of Gender
 - 75 Research and Extension GAD related Programs, Activities and Project conducted (PAP's) attributed

Organization-Focused Activities

5. To strengthen Gender Mainstreaming through recognition of GAD implementation in the University/ Magna Carta of Women (RA 9710)
- Provide recognition and award to GAD implementer and other GAD-related award (GAD implementer for students and employees, GAD Advocate Award)
 - Attributed Gender and Development Advocate Award (PRAISE Everlasting Awards year 2022) awarded to College of Home Economics & Technology during the BSU 106th Foundation Anniversary Celebration, PRAISE Everlasting Awards; September 29, 2022
6. To enhance GAD mainstreaming in Administration, Academic, Research and Extension, Production/ Magna Carta of Women (RA 9710)
- Conduct GAD related Gender Mainstreaming capability building training/workshop/fora summit appropriate for the GAD Thematic Areas: Advocacy & trainings/Gender in environment/DRRM/GAD responsive infrastructure project/Learning and Development
 - Conducted GAD related PAP's in collaboration with HRDO and other offices/ colleges: Diet and Physical Fitness for Geriatrics, Akay Para Kay Inay: Discussing Prenatal and Postpartum Diaries, Mother's Day, Gender Sensitivity Training to stakeholders, ThinkTalk: Language, Literature, Arts and Communication Series, "Employees Juana Ride" with Orientation on Gender and Development Concepts to the community, and Sports/ wellness (Fun Run and BSU Men and Women Darts Tournament)
7. To integrate gender perspective in higher education research as part of gender responsive research program
- Conduct gender responsive researches through the use Gender analysis and Harmonized GAD Guidelines for Researchers
 - On-going Project and study from June 2022 to December 2025 spearheaded by the Institute of Social Research and Development
 - ❖ Program Title: Tracing the Milestone of Gender and Development in Benguet State University (Duration June 2022 to December 2025), Program Leader: Gigy G. Banes, ISRD, CSS
 - ❖ Project 1: Project Title: - Assessment of the Process and Implementation of Gender and Development in Benguet State University (Duration June 2022 to December 2025), Program Leader: Imelda G. Parcasio, CTE
 - Study 1- Study Title: BSU Gender and Development: Three Decades of Implementation, A Documentation (Duration June 2022 to December 2025), Program Leader: Imelda G. Parcasio, CTE
 - Study 2- Study Title: Evaluation of GAD Mainstreaming in the 4-Core Functions of Benguet State University for the Past Decade(Duration June 2022 to December 2025), Program Leader: Freda Kate D. Samuel, CNAS

- Study 3- Study Title: Policies Crafted GAD Perspective (Duration June 2022 to December 2025), Program Leader: Renebeth G. Donguiz
 - ❖ Project 2: GAD Mainstreaming in Academics/ Instruction (Duration June 2022 to December 2025), Program Leader: Cynthia T. Lubiton, CAH
 - Study 1- Study Title: Integration of Gender Perspectives in the Tertiary Level Curriculum of Benguet State University (Duration June 2022 to December 2025), Program Leader: Gigy G. Banes, ISRD, CSS
 - Study 2- Study Title: Gender Narratives from SSP 23 Students Outputs (Duration June 2022 to December 2025), Program Leader: Ann Heather B. Kiwang, CSS
 - Study 3- Study Title: GAD Mainstreaming in Teaching: Teachers Capability, Extent of Implementation, Issues and Concerns (Duration June 2022 to December 2025), Program Leader: Cynthia T. Lubiton, CAH
 - ❖ Project 3: GAD Mainstreaming in Research And Extension (Duration June 2022 to December 2025), Program Leader: Chester B. Esnara, Bokod Campus
 - Study Title: Study 1- Gender Mainstreaming in Research: A Review of Gender related Researches in Benguet State University from 2001- 2021 (Duration June 2022 to December 2025), Program Leader: Chester B. Esnara, Bokod Campus
 - Study Title: Study 2- Gender Mainstreaming in Extension (Duration June 2022 to December 2025), Program Leader: Nora C. Sagayo, CA
 - Study Title: Study 3- Assessing the Impact of Capacity Buildings for Students and Employees (Duration June 2022 to December 2025), Program Leader: Shakira B. Herman
 - Workshop and writeshop conducted on Research proposal instruments, conceptualization on Research proposal on documentation and Assessment of GAD Mainstreaming in BSU and on Tracing the Milestone of GAD in BSU
8. Inadequate support services for personnel/students with young children and breastfeeding mothers (affecting productivity, especially among women non implementation of RA 10028)/Magna Carta of Women (RA 9710)
- Establishment of new breastfeeding station and maintenance of established stations
 - Launching of the BSU Bokod Lactation Room; April 11, 2022; BSU Bokod Campus
 - Launching of the BSU Buguias Campus Breastfeeding Station; March 30, 2022; BSU Buguias Campus
 - Launching of CHET Lactation Room; May 16, 2022, CHET Building
 - Fully maintained Lactation rooms at BSU Administration, La Trinidad
 - Procurement of needed supplies and materials
9. Ensure opportunities of personnel and students to have access on agency care services to children to avoid absenteeism
- Establishment and maintenance of Child-Minding Center for working parents in ensuring that they have a safe place to leave their child while they are at their work places
 - Launching of the BSU Bokod Campus Child Minding Center; April 11, 2022; BSU Bokod Campus
 - Launching of the BSU Buguias Campus Child Minding Center March 30, 2022; BSU Buguias Campus
 - Fully maintained Child Minding Center at College of Agriculture, La Trinidad
 - Procurement of needed supplies and materials
10. Strengthened GFPS in order to implement GAD PAP's and advance GAD Mainstreaming (GM) in the University
- Capability building/ training for GFPS: GMEF/HGDG/GPB/GAD Agenda/GAD Deepening Session and TO among other related trainings and capacity building activities (Regional/ National GAD-related trainings/ seminars/ forum/workshop)
 - Conducted and attended GAD related PAPs: GAD Plan and Budget 2023, 2022 GAD Accomplishment Report and Training of Trainors (ToT) of BSU GFPS- Technical Working Group Members, Cordillera GAD Focal Point Sytem (GFPS) Assembly, International Conference and other trainings for each GFPS-members on GAD related updates and mandates
11. To ensure operations of GAD Office as well as monitor and evaluate GM efforts of the University
- Regular coordination and meetings of GAD-GFPS (Execom, GFPS- TWG members and external campus TWG members) and emergency meeting when necessary
 - GFPS-TWG Regular meetings/ other Committees related to GAD conducted and attended
 - >BSU GFPS-TWG Members regular meeting
 - >Regional Gender And Development Committee (RGADC) Quarterly Meeting
 - >RGADC Women's Month Celebration 2022 TWG Member Meeting
 - >CAR GFPS Assembly TWG Meeting
 - >RGADC Violence Against Women Month Celebration 2022 TWG members Meeting
12. To increase awareness of personnel & reinforce GAD concepts to employees
- Conduct Gender Sensitivity Training for newly hired Personnel (continuing activity)

- Attributed HRDO Career Ladder Jumpstart Orientation (CaLaJO) II with Gender Sensitivity topic from the; April 29, 2022, BSU, LTB
13. To ensure operations of GAD Office as well as monitor and evaluate GM efforts of the University
 - Engage support staff to assist in the implementation of GFPS PPA's and Gender Mainstreaming in the university through rehiring of GAD staff and SA
 - Attributed salary of GAD staff
 14. To increase the provision of adequate and accessible library and related learning materials across various disciplines and educational levels
 - Provision of knowledge products (books magazine, multi-media) for adequate and accessible library and related learning materials in support to gender-responsive Curriculum Programs
 - Attributed procured library, learning materials and subscriptions by the University Library Services
 15. Integration of gender mainstreaming in curriculum or subjects in all levels/ Part V of CMO 01, s2015 on establishment of Gender-Responsive Curricular Programs/CMO 01, s. 2015
 - Preparation of syllabi and classroom teaching integrating gender perspective
 - Attribution of PS BSU Teaching personnel in La Trinidad, Bokod and Buguias Campus for the presence of an institutionally-developed instructional materials- Adoption of institutional academic materials on developing gender-sensitive learning materials
 16. To establish a centralized GAD-related database of the University
 - Continuous data gathering and consolidation of Sex-Disaggregated Data (SDD) and other data related to personnel/students/clients in the University for centralized GAD database for gender analysis and report preparation
 - Attributed GAD database
 - SDD of BSU Personnel- Human Resource Management Office
 - SDD of Students enrolled- Office of the University Registrar and Admission
 17. To ensure the implementation and relevance of Gender Mainstreaming in the University through the sustained annual GAD- PAPs and to sustain the presence of a GAD Office where employees, students and stakeholders can direct their queries and concerns and where GAD efforts will be coordinated
 - Maintenance of the GAD Office to implement Gender Mainstreaming in the University and sustaining GAD Office in the campuses as repository of knowledge products, office equipment, reports and making available GAD service staff
 - Fully maintained GAD Office
 - Procurement of supplies, equipment and materials for GAD PAPs
 - Attributed salary of GAD Director
 18. Increase knowledge and skills on gender-related concerns necessary to prepare and respond to disasters or emergency composed of equal men and women
 - Conduct training to address the gender issues and concerns that necessary to prepare and respond to disasters or emergency composed of equal men and women
 - Conducted DRRM Fire Suppression and Emergency Management (Disaster Risk Mitigation and Containment Measures) to BSU La Trinidad, Bokod and Buguias Campus employees (Teaching and Non-teaching) together with HRDO and in collaboration with Bureau of Fire Protection- CAR, La Trinidad Fire Station
 - Batch 6; September 15, 2022; BSU Gymnasium, Closed Gymnasium and Oval
 - Batch 5; September 14, 2022; BSU Gymnasium, Closed Gymnasium and Oval
 - Batch 4; August 4, 2022; BSU Gymnasium, Closed Gymnasium and Oval
 - Batch 3; July 26, 2022; BSU Gymnasium, Closed Gymnasium and Oval
 - Batch 2; July 25, 2022; BSU Gymnasium, Closed Gymnasium and Oval
 - Batch 1; March 24, 2022; BSU Gymnasium, Closed Gymnasium and Oval
 19. Enhanced support services for employees in need of special leaves/ Compliance to Section 18 of MCW RA 9710 Special Leave Benefits for Women, RA 8187: Paternity Leave Act of 1996, Section 8 of RA 8972 Solo Parents Welfare Act of 2000, Section 43 of RA 9262
 - Provision of gender leaves
 - Attributed 100% Maternity, Paternity, Solo parent, gynecological, VAWC leave of employees who will availed
 - SDD of BSU Personnel- Human Resource Management Office
 20. To strengthen awareness of BSU students/ employees on women's rights and their role in national development and nation building

- Participation to 18-Day Campaign to end VAW and Women's Month Celebration/ activities and programs organized by PCW
- National Women's Month Celebration (NWMC) Activities 2022
 - BSU La Trinidad Campus Flag Raising Ceremony: Kick-off Program and Caravan ni Juana and distribution of Juan kits and Juan kits
 - BSU Employees Juana Ride
 - Juana Virtual Run
 - Gender Mainstreaming and Skills Training on Dish Garden and Open Terrarium during the NWMC 2022 (BSU Bokod and Buguias in collaboration with the HORTI)
 - Celebrating 2022 Women's Month Through Virtual Photo Essays on Gender and Indigenous Knowledge Systems (IKS)
 - Community-Based Screening-Breast, Pelvic and Cervix (in collaboration with College of Nursing)
 - Posting of NWMC Banner
 - 2022 Women's Month Celebration BSU Bokod Campus:
 - Flag Raising Ceremony, Distribution of Information materials, Education and Communication (IEC) Campaign, Posting of NWMC Banner, #PurpleTuesdays, Search for Biggest Loser Season 3 Challenge, "Kadkarang"
- 2022 18-Day Campaign to End-Violence Against Women (VAW)
 - Kick-off of the BSU 2022 18-Day Campaign to End Violence against Women, "United for a VAW-free Philippines";
 - BSU "VAWalk" conducted at La Trinidad, Bokod and Buguias Campus
 - Orientation Forum on Safe Spaces Act and Gender-Based Violence at BSU La Trinidad, Bokod and Buguias Campus
 - Distribution of VAWC Advocacy shirt
 - Distribution of IEC materials to raise awareness on VAW
 - "Orange You Icon" at Lobby of Administration, BSU, La Trinidad
 - BSU family joined the Regional Gender and Development- Cordillera Administrative Region (RGADC- CAR) parade and Closing Ceremony
 - BSU International Mens' Ride 2022
 - Culminating Program for the 2022 18-Day Campaign to End-Violence Against Women (VAW) and Zumba session with awarding of winners for the Traditional Poster Making and Digital Poster Making

Attributed Programs, Project and Activities

- Improvement of BSU College of Forestry Nursery
- BSU Covid-19 Response 2022
- Improvement of the BSU Bokod Campus road network
- Improvement of BSU water tank
- Improvement of BSU College of Forestry (Continuing 2021)
- Terminal Report, Harmonized Gender and Development Guidelines (Box 16.GAD Checklist for Project Management and Implementation, Box 17.GAD Checklist for Project Monitoring and Implementation)

Other office accomplishments:

- BSU GAD Briefer
- Reconstitution of GAD Focal Point System- Technical Working Group (GFPS-TWG) members 2023-2024